

Everything you never wanted to know about intervals

Much to my surprise, it turns out that making and recognizing intervals is one of the more difficult skills for beginning students to master. I hope this handout can make things a little more clear.

An *interval*, of course, refers to the distance between two notes.

Distance between note-names or staff lines

In the most basic sense intervals are referred to as “seconds,” “thirds,” “fourths” and so on. These terms refer to the number of note-names or staff lines that separate the notes.



$B\flat \rightarrow B$

The distance of a note to the same note would be a “first.” Except you don’t say first, you call it a “*unison*”

$C \rightarrow D$

The distance from one note to the next name or staff line is a *second*. Often we say “step” instead of second.

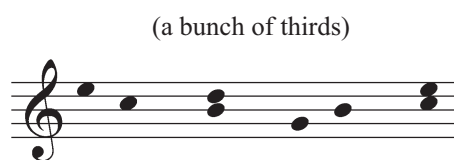

Ⓒ D Ⓔ

Skipping over one note makes a *third*.

And so on for fourths, fifths, etc.

The qualities of intervals - major, minor, perfect, augmented, diminished

It turns out that all seconds, thirds, etc. are not exactly the same size - we've got to get a little more specific. The best way to figure out the exact distance between two notes is to think of them on a piano keyboard - this way you can actually count the half steps in between. Consider these two different thirds on the piano.

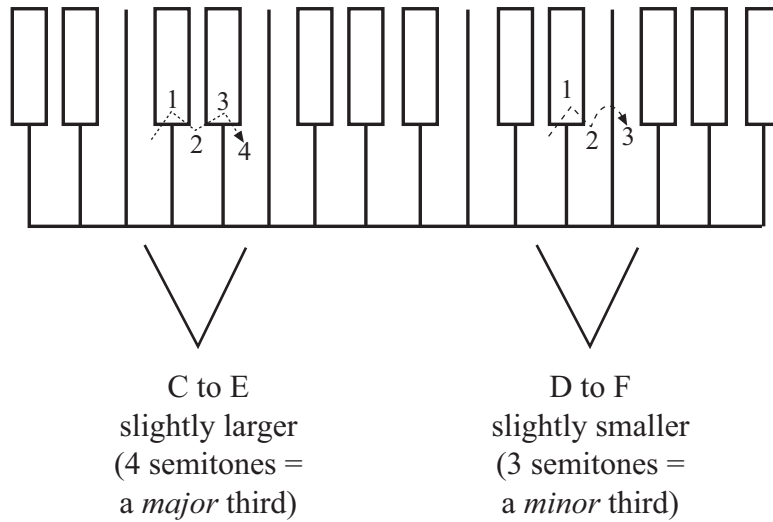

Perfect vs. Imperfect Intervals

There are two different types of intervals - perfect and imperfect.

For the perfect intervals (the unison, fourth, fifth, and octave), there is one size that is considered the "normal" or most common size. We refer to that as the "perfect" interval. If you make the interval a half-step bigger than normal it is "augmented," whereas a half-step smaller than normal is "diminished."

Perfect Intervals: Unison, 4th, 5th, Octave

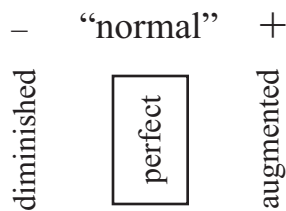

The other intervals (2nd, 3rd, 6th, and 7th) are imperfect. Rather than one normal size, they've got a larger variety (major) and a smaller size (minor). Both of the major and minor intervals can be considered normal, but occasionally a major interval is "stretched" even larger, making it augmented, or a minor interval is made smaller, or diminished.

Imperfect Intervals: 2nd, 3rd, 6th, 7th

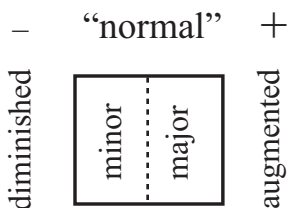

Figuring the size of intervals

I suspect the average musician uses several different ways to calculate the size of intervals.

Size in semitones: The simplest and most efficient way to define an interval is to count how many half-steps or semitones are in it. We saw this in action on the previous page when we noted that a minor third has 3 semitones and a major third has 4. This works well for small intervals, but of course it will become annoying to count up, say, 9 semitones on your piano keyboard.

Scalar segments: An alternative to counting all semitones is to think of the interval as part of a scale. When you reckon from the first note in the scale, the major scale provides all of the major intervals, and the minor scale provides the minor ones.
(see my diagram on the next page)

Intervals in the major scale

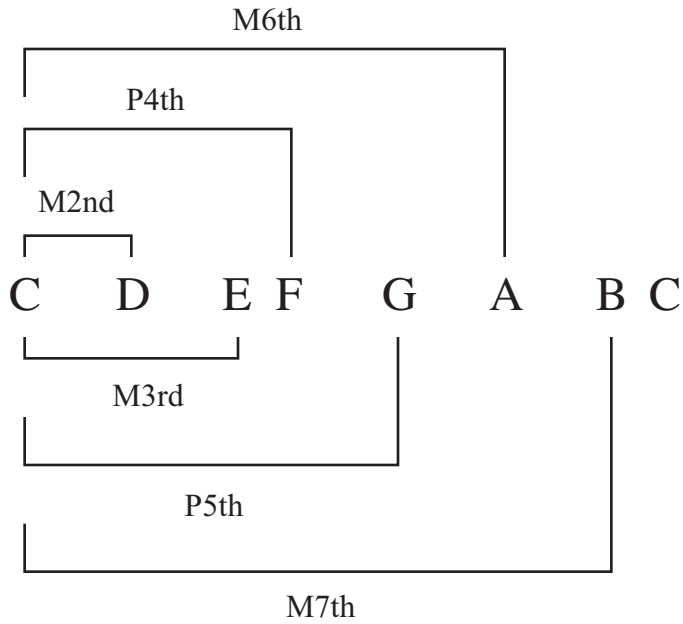

so it would make sense to build any major third out of two whole steps...

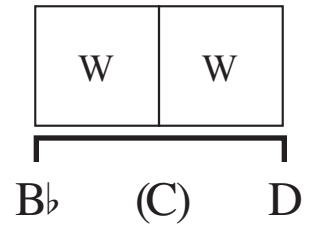

Intervals in the natural minor scale

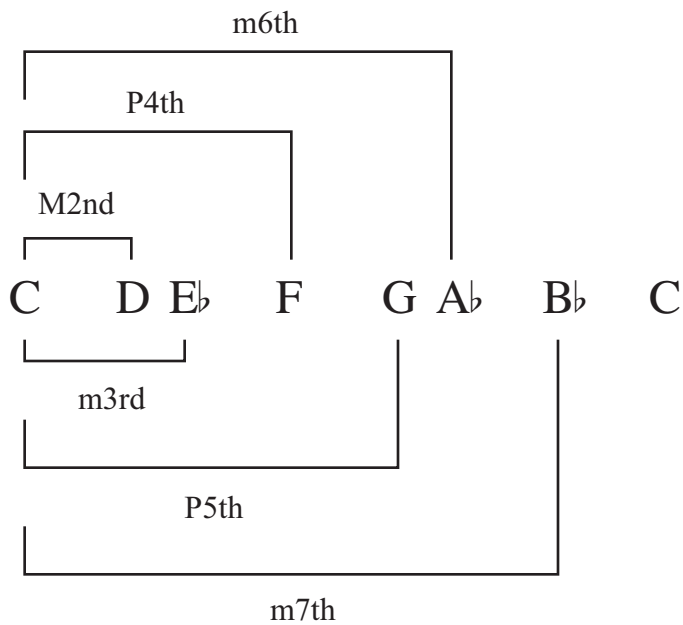



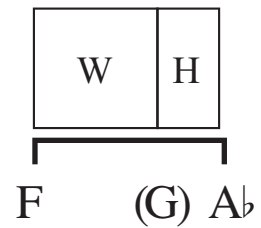

so it would make sense to build any minor third out of a whole step and a half...



Guide to smaller intervals

We've got all we need to start making the smaller intervals. Here's a guide to the more common ones.

		SIZE IN SEMITONES				
		1	2	3	4	5
Unison	As I've mentioned, this is the distance from one note to the same note. It is theoretically possible to have "augmented unisons" or "diminished unisons," but a more commonsense approach would simply be to call those half steps or semitones.					
	"aug unison" (half step)					
Minor 2nd A.K.A. half step, semitone		m2				
Major 2nd A.K.A. whole step		maj 2nd				
Augmented 2nd This "special" interval is actually somewhat common. It occurs in the harmonic minor scale. It's the same size as a minor 3rd, 3 semitones.		aug 2nd				
Minor 3rd 3 semitones, or W+H. Found in the first three notes of the minor scale.		minor 3rd				

SIZE IN SEMITONES

1 2 3 4 5 6 7

Major 3rd

4 semitones, or W+W. Found in the first three notes of the major scale.



major 3rd

Perfect 4th

5 semitones, or W+W+H. Found in all scales.



perfect 4th

Augmented 4th / Diminished 5th / Tritone

This special interval is famous because it is somewhat difficult to sing. The interval between P4th and P5th (6 semitones) is also known as the “tritone” because it could be built W+W+W. (In reality, though, you will probably think of it in other ways most of the time.)

This is one situation where the way you spell the interval is crucial. (See more on the “enharmonic error” on the next page.) Starting with a P4th and “stretching” it produces an augmented 4th (say, C-F#), whereas starting with a P5th and shrinking it would make a diminished 5th (C-Gb). Note how they look different on the staff:



aug 4th / dim 5th

Perfect 5th

7 semitones, or W+W+H+W. Found in all scales.



perfect 5th

The “Enharmonic Error”

When two differently-spelled notes land on the same key on the piano we say that they are “enharmonically equivalent.” C# and Db are a good example - they are both played on the same black key. (So what’s an enharmonic equivalent of Cb? Bbb?)

It’s possible to spell different intervals that are the same size. I’ve already mentioned that the augmented second and the minor third are the same size, as are the augmented fourth and diminished fifth. The bad news is that enharmonically equivalent intervals are NOT considered interchangeable in tonal theory -- they supposedly imply very different contexts (different scales, different melodic continuation, etc.) Some theorists would even argue that they are tuned differently on instruments other than the piano. Thus, if I ask for an augmented fourth and you write a diminished fifth I will probably say that you’ve made “an enharmonic error,” or, if I’m feeling cranky, “that’s not a fourth!”

Avoid this error by paying attention to the very first paragraph in this packet. Remember that fourths all look a certain way on the staff and skip a certain number of note-names. Fifths look bigger on the staff, even if they are diminished.

Interval Inversion

Imagine you’ve got a major third from F up to A, like so:



What would happen if the note on the bottom were flipped onto the top, or vice versa? Our major 3rd would suddenly become a minor 6th. This happens all of the time in music, and we refer to it as “inversion.”



It is easy to predict what an interval will turn into if inverted.

First, you must learn which intervals are “opposites” of each other. (If you want, you can remember that the numbers add up to nine, though I think it’s more intuitive to just memorize them like so:)

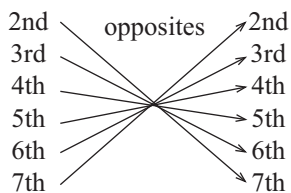
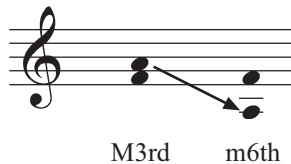

You could think of the interval and its inversion as the two parts that would add up to an octave.

Plus, the qualities of intervals will be opposite (except for perfect intervals, which remain perfect.)



M3rd + m6th = 8ve

major ↔ minor

augmented ↔ diminished

perfect ↔ perfect

Making Larger Intervals - Using the Inversions

Knowing your inversional equivalents is very useful in making larger intervals. It can be confusing to count up a M7th (= 11 semitones or W+W+H+W+W+W) from a particular note. Thus, it is useful to know that “any interval up is the same as its inversion down.” (To be exact, the inverted interval hits the same note as its opposite, only an octave down.) A M7th up is the same note as a m2nd (or half-step) down.

Say you are asked to build a m7th up from F. First, calculate the inverted interval (M2nd) down.

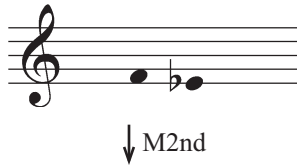

Then, flip that note around so that it's on top.



This is especially useful when you need to make a larger interval going down from a note instead of up. Remember that “a m7th down is the same as a M2nd up” etc.

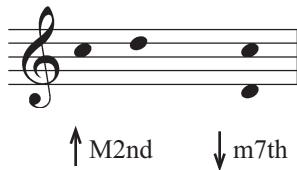

Larger intervals as a 5th + a small interval

Yet one more trick you could use to make large intervals is to count up from the perfect fifth. I definitely do this when dealing with 6ths. Here is a table that shows you the two ways you can think of the large intervals.

large interval	inversional equivalent	5th + small interval
m6th	M3rd	P5th + m2nd
M6th	m3rd	P5th + M2nd
m7th	M2nd	P5th + m3rd
M7th	m2nd	P5th + M3rd
dim 7th	aug 2nd	???

Augmented and Diminished Intervals

These are perhaps the most tricky intervals to spell. I like to start with a more common interval and “stretch” or “squish” until I get the augmented or diminished version.

First, you’ve got to remember how these intervals relate to “normal” perfect and imperfect ones!

Perfect Intervals: Unison, 4th, 5th, Octave

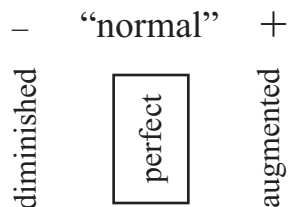

Imperfect Intervals: 2nd, 3rd, 6th, 7th

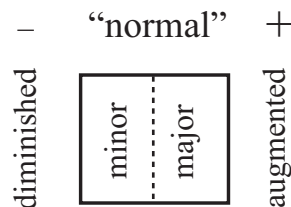

Now, say you were asked to create a somewhat unusual interval, an augmented sixth ascending from F.

First you could start with a major sixth...



then raise the top note an extra half step for an augmented 6th.



Be careful when making *descending* intervals, though. You’ll end up pushing the notes the opposite way in order to “stretch” or “squish”!

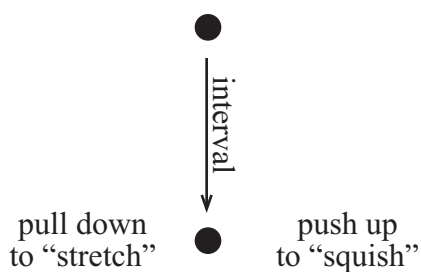

So if you are making a descending diminished fifth from C, create a perfect down and then “squish” it.



(push up bottom note)

Also, remember you can check your work by inverting. A diminished interval will invert to an augmented one, and vice versa.